



Edition : 1.0
Date: (11/24)

Instruction Manual

INDUSTRIAL TOOLING CABINET TC-900

Order Code: (T775)

BEFORE ASSEMBLING

Please read this instruction manual before assembly.



CAUTION

Before assembly please pay attention to the following points in priority;

Confirmation of components: Before assembling, please confirm all parts arrived and are in good order.

Site for assembly: Please assemble it on the soft floor such as smooth carpet and flannel blanket. When you assemble on wooden floor, please put thin towels on the floor.

Points for attention when assembling: Please wear gloves to ensure that it can be assembled safely, and use two persons to help in the assembly process.

Matters needing attention for operation:

- Do not use for in proper use.
- Do not use it on inclined surface or uneven places.
- Do not use it when screws and fasteners are loosened.

TOOLS REQUIRED FOR ASSEMBLY

- M6 & M8 spanners
- Phillips Head Screwdriver

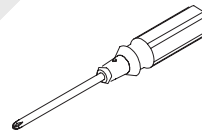
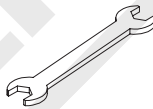

PARTS LIST

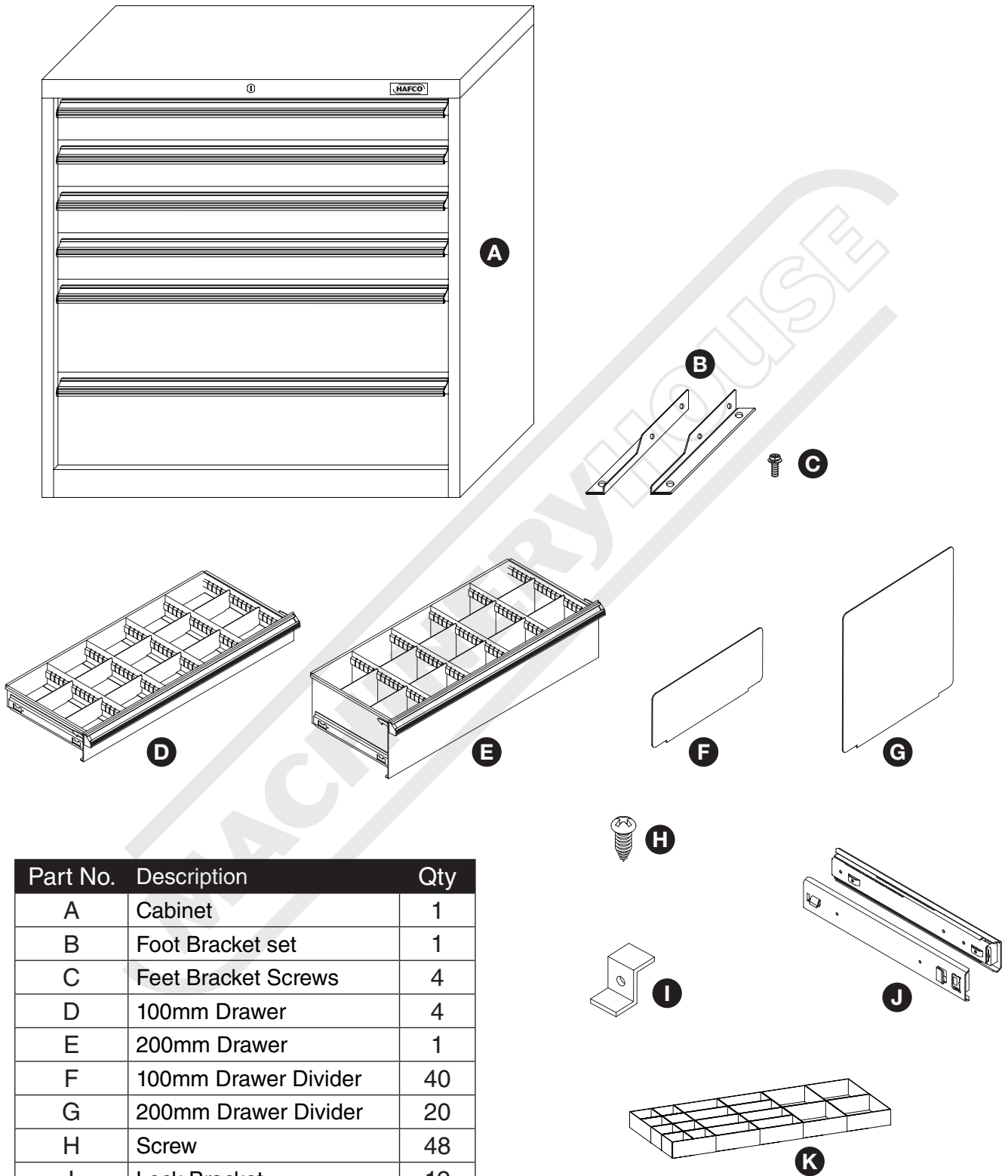

Part No.	Description	Qty
A	Cabinet	1
B	Foot Bracket set	1
C	Feet Bracket Screws	4
D	100mm Drawer	4
E	200mm Drawer	1
F	100mm Drawer Divider	40
G	200mm Drawer Divider	20
H	Screw	48
I	Lock Bracket	12
J	Drawer Slide Set	6
K	Plastic Buckets Assorted	20

ASSEMBLING of Feet

STEP 1: Attach the feet brackets (B) to the base of the cabinet (A) and fix into place with screws (C) as shown below.

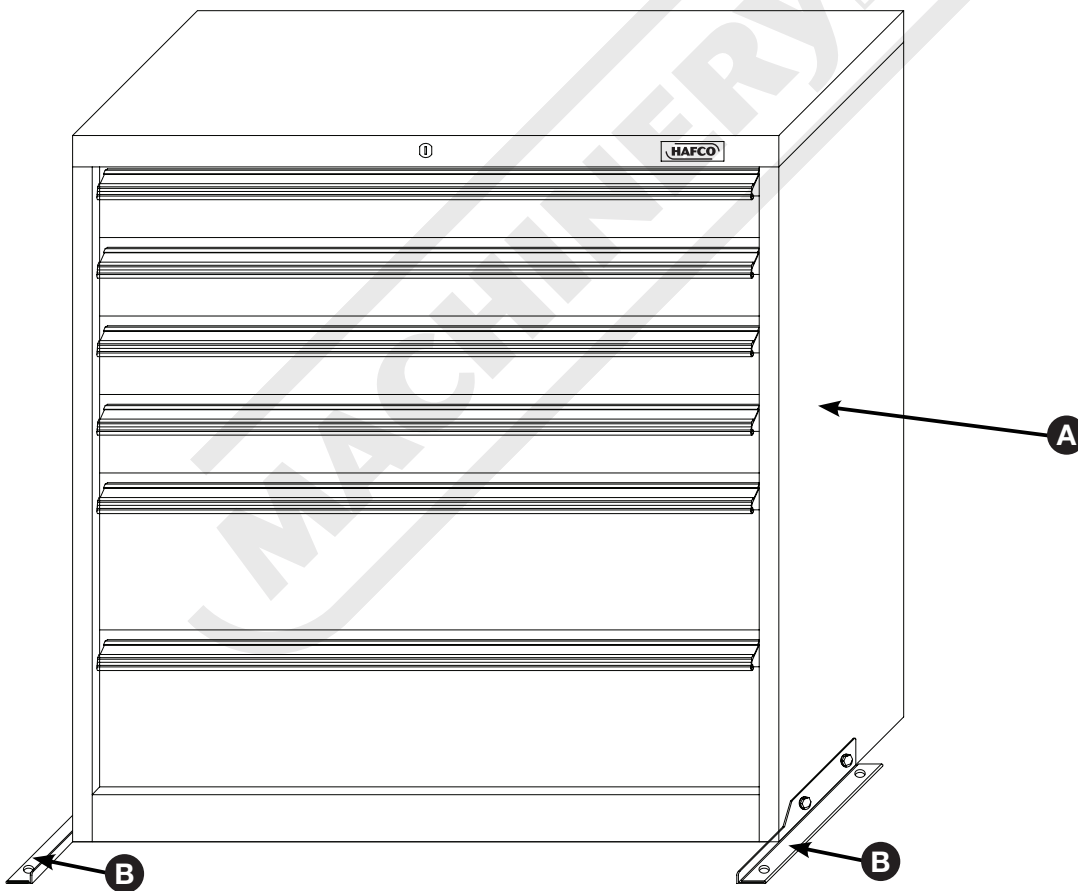
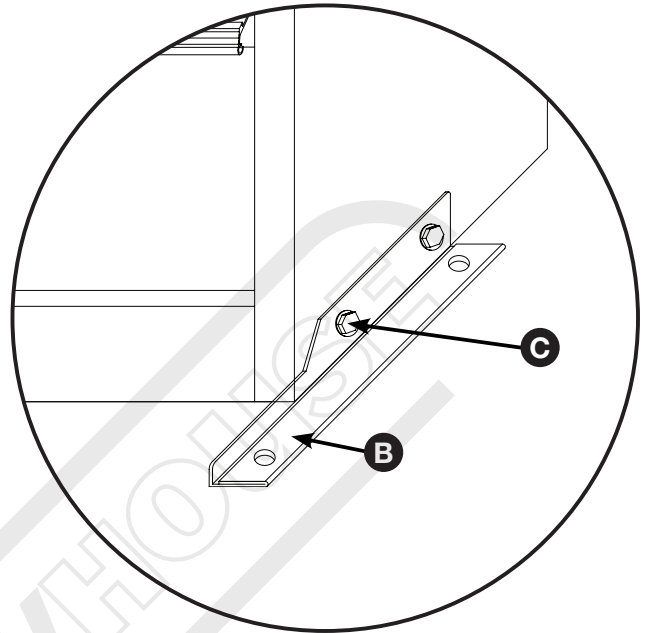

DRAWER ASSEMBLY

STEP 1: Insert drawer dividers (F & G) into the corresponding drawers (D & E) as shown below.

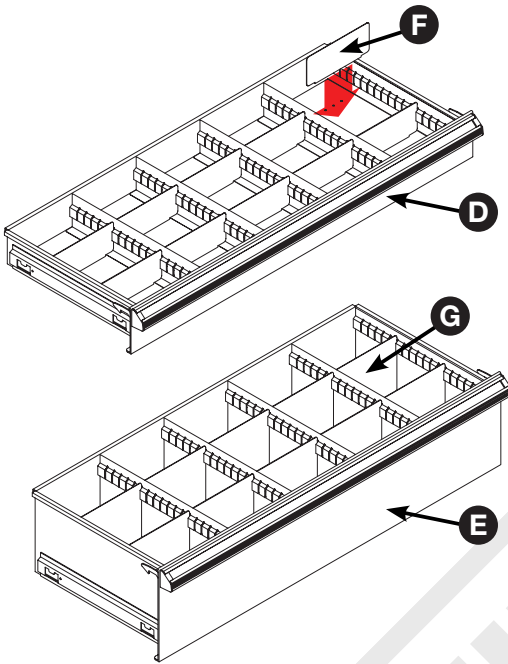

STEP 2: Slide apart the drawer slide sets (J) by pushing up or down on the plastic release levers (J2). Now attach brackets (J2) into slots on both sides of drawers (D & E) and fix in place with 2 screws (H) on each bracket (J2) as shown below.

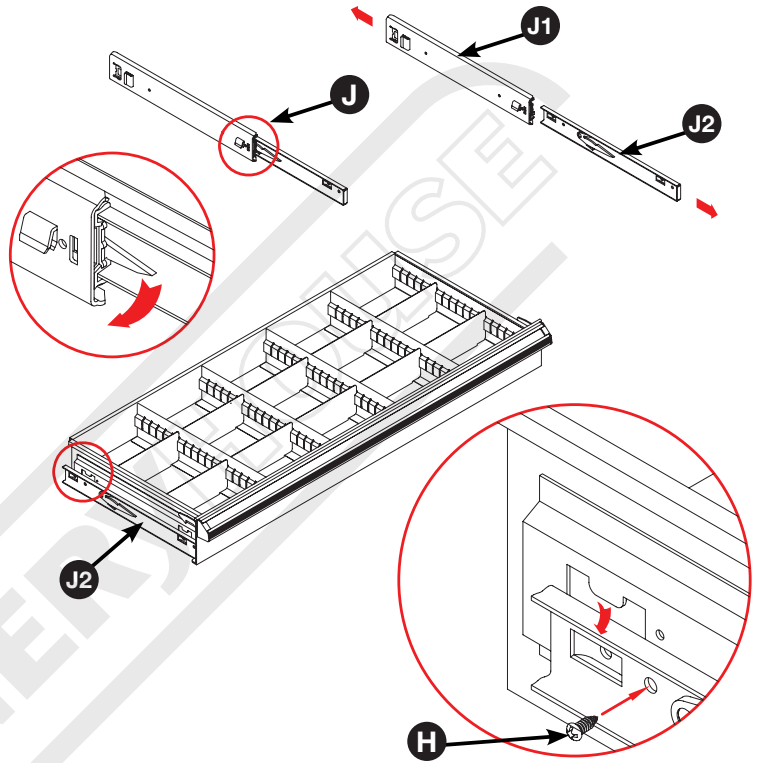

STEP 3: Insert the drawer slide brackets (J1) into slots on at desired height on both sides of cabinet body then fix in place with 1 x screw (H) per bracket (J1). Insert the lock bracket (I) into the slot above the drawer slide bracket (J1) and fix with screw (H). Height of bracket (I) is adjusted with the size of drawers.

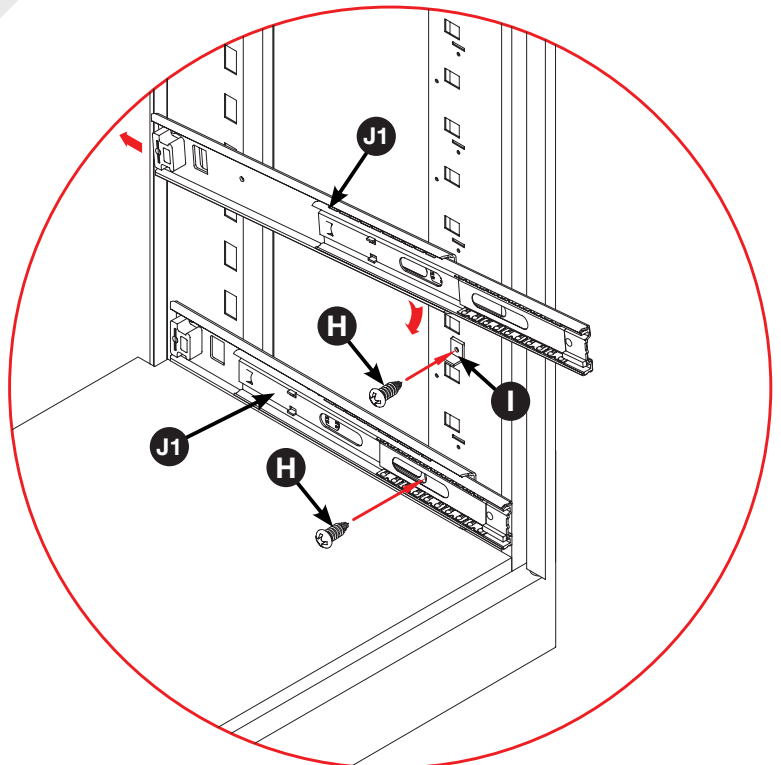

DRAWER ASSEMBLY Cont...

STEP 4: Extend the drawer slides (J2). Insert the brackets on each side of the drawer into the slots on the slides (J1), being careful that they are properly positioned. Once properly inserted, completely close the drawer to set the slides in their proper positions.

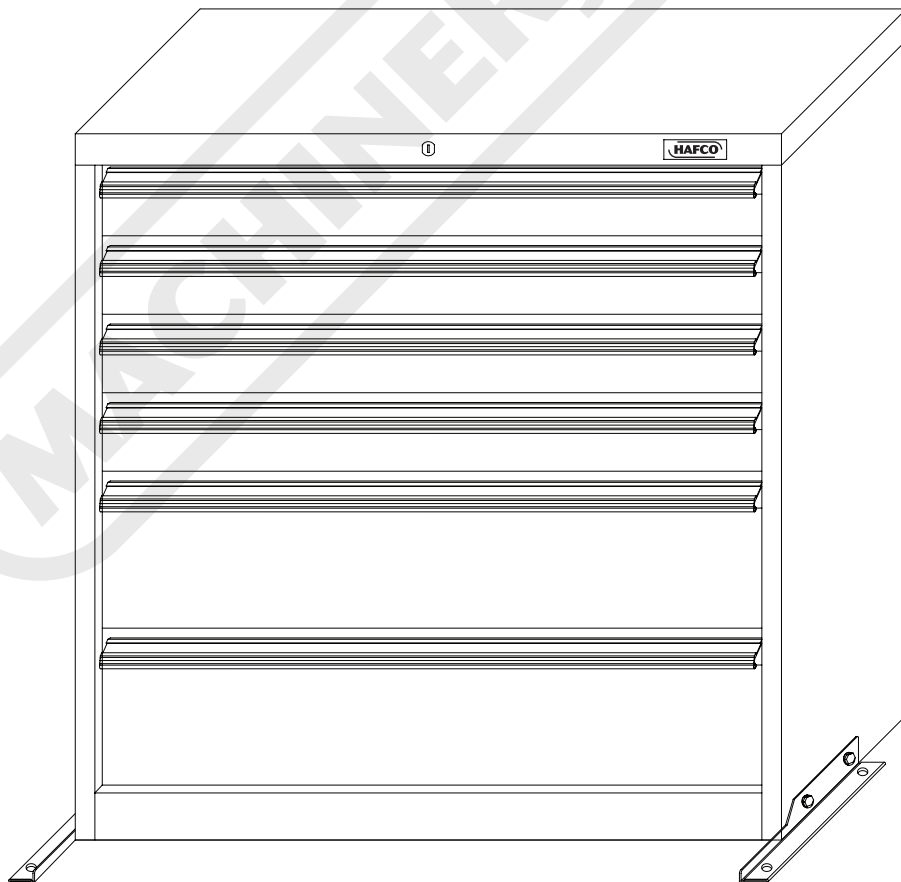
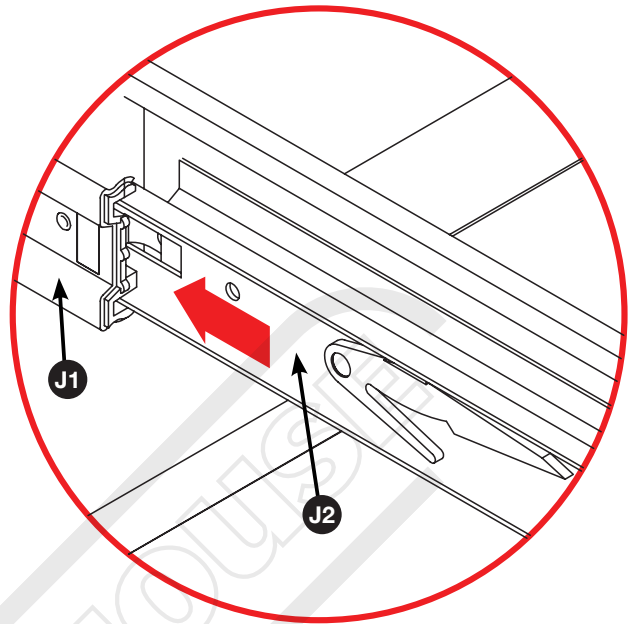



ENVIRONMENT PROTECTION

Recycle unwanted materials instead of disposing of them as waste. All tools, accessories and packaging should be sorted, taken to a recycling centre and disposed of in a manner which is compatible with the environment. When the product becomes completely unserviceable and requires disposal, drain any fluids (if applicable) into approved containers and dispose of the product and fluids according to local regulations.

Imported by

HARE & FORBES
MACHINERYHOUSE

Australian Distributor

Hare & Forbes
Machineryhouse
Sydney - Melbourne
Adelaide - Brisbane - Perth

Ph: 1300 202 200
www.machineryhouse.com.au

MACHINERYHOUSE

New Zealand Distributor

Machineryhouse
Auckland
Christchurch

Ph: 0800 142 326
www.machineryhouse.co.nz